

Timber Windows and Doors



Conservatories Orangeries Windows Doors Hardwood Softwood



Naturally beautiful



Why choose timber windows

Timber is the number one green choice for building in the 21st century, a wholly natural, organic and renewable product that is waste-efficient, bio-degradable and non-toxic, and has a character and charm unrivalled by man-made alternatives. Sustainability is at the heart of the company's purchasing ethos, and all timber is either plantation-grown, or from managed forests. Supplies are obtained from suppliers who carry FSC, PEFC, or MTCC certification, so you can be sure the timber is not logged from illegal sources.

Carbon-neutral

Trees naturally absorb carbon dioxide (CO₂) and young, growing trees absorb more than older, mature specimens, which supports the validation of managed felling and replanting programmes. Forests are vital in the crusade against climate change.

WWF endorsement

A recent WWF report concludes timber windows are better for the environment than PVC windows, and specifiers are encouraged to choose timber sourced from well-managed forests or other controlled sources, and to ensure that the timber is obtained legally.

Timber

A range of manufactured hardwoods is available in solid timber or engineered timber: Meranti; Red Grandis; Sapele or European Oak. Engineered softwood in the form of European Redwood, is also available. All of these timbers are obtained from managed forests.

The manufacturing process

The manufacturers are based in rural Oxfordshire and have a team of dedicated craftsmen and technicians who possess many years of skill and experience in timber manufacturing. Windows and doors are constructed using traditional methods allied with modern technology, and this winning combination delivers a product that is beautiful in appearance, skillfully crafted and very practical.

The process begins when each timber component is carefully selected by a technician, who checks it for colour, quality, and integrity, and ensures it has been tested for the correct moisture content before committing it to the manufacturing system. Once the frames are assembled they are carefully hand-sanded and inspected before being transferred to the finishing process.

The finishing process

The windows are sanded by hand and prepared before each stage of the paint process, which involves dipping the frames in an antifungicidal base coat of paint and then finished with two spray coats in the colour of your choice. A colour chart is available on request, which includes a handful of colour choices, but any of the proprietary colours can be matched, such as Farrow and Ball, Fired Earth, BS or RAL. Colours can also be matched to any samples provided. Different coloured sashes and frames, or different inside and outside colours are not a problem for our specialised finishing department. With all colours, a painted board sample will be provided for approval.

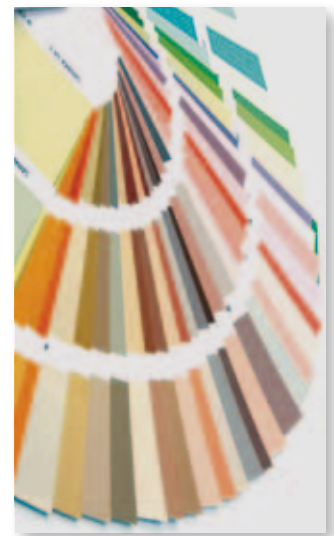

Glass

Sealed units or double-glazed units are either 28mm in stormproof systems, and 24mm in all other systems, both giving optimum performance. Glass will normally be clear, with a low e-coating, a warm-edged spacer bar, and filled with argon gas. Various other glass enhancements and decorative features are available, such as leaded glass, astragal bars, laminated glass, self-cleaning glass, acoustic glass, mirrored glass and any other commercially-available glass.

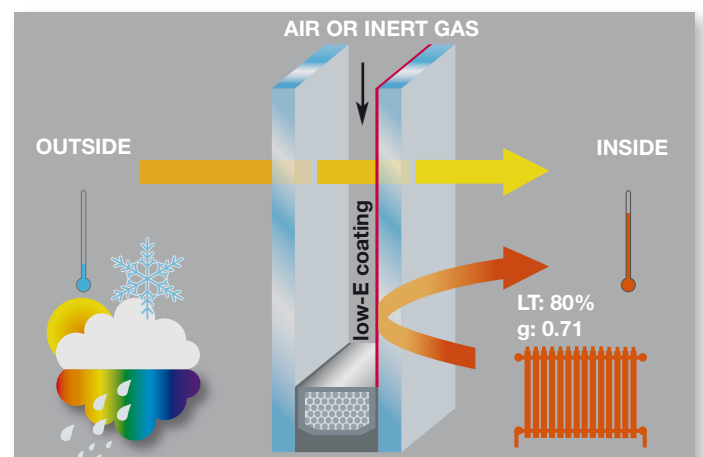



Stormproof Windows

Stormproof windows

Top quality stormproof windows are based on a standard timber model that was introduced in the 1950s. The sash of the window is lipped, or rebated, over the frame, which affords a better weatherproofing than the flush casement window.

Careful planning and design has brought this basic design right up to date to accommodate modern shootbolt handles and multipoint shootbolt locking mechanism for high security. Stainless steel friction hinges facilitate ease of opening and easy cleaning.

The stormproof window has been specifically designed to incorporate double weatherstripping: one weatherstrip to the sash, and one weatherstrip to the frame. This provides maximum draught sealing, and gives you the flexibility of deciding whether or not you wish to ventilate.

The high-performance 28mm sealed units give the optimum 'U' value performance for building regulations approval. The 'U' values can be further enhanced by using a higher specification glass.

Glass decorations include astragal bars, diamond or square leaded patterns, and bevelled glass.



White stormproof window with astragal bars



Light oak stormproof window with diamond leads



Dark oak stormproof window with swept heads and a cottage bar

Basic window options

There are many different options to choose from of which these are just a few. Windows can be manufactured fully bespoke to suit any situation, for example, special windows for listed buildings, including single glazing, special profile sizes and designs.

1. There are two choices of frame depth: 69mm and 90mm.
2. The outer frame profile can be either ovolo as shown or square.
3. The sash shoulder can be either ovolo, square, or chamfered.
4. The glazing bead can be either ovolo, square or chamfered.
5. The sash stormproof profile can be either ovolo, square or chamfered.

All of the profile choices mentioned above are interchangeable, for example you could have an ovolo outer frame profile, with an ovolo sash shoulder, a chamfered stormproof profile and a chamfered glazing bead.

The cross section shows the windows as externally glazed, but they can also be internally glazed.

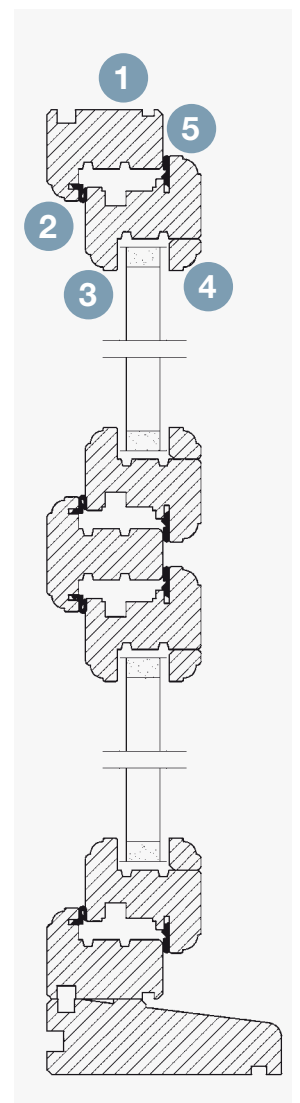

The stormproof window can be made to virtually any shape or size to suit requirements



Traditional Flush Windows

Traditional flush windows

Traditional flush windows are so-called as they are based on a traditional tried and tested pre-1950s design. The similarity between these and our modern window is the sashes are flush with the frame on the outside. However, that's where the similarity ends, for the design has now been brought right up to date, combining the best of both worlds: traditional appearance with modern multipoint shootbolt locking, shootbolt handles and stainless steel friction hinges.

It is possible to retain the traditional style of window design by incorporating butt hinges and shootbolt handles; a traditional peg and stay at the bottom of the sashes is also available, if required.

A host of other options are available with, for example, the standard flush window, some of which are listed on the cross-section opposite, but other choices are available such as floating mullions or, subject to style, dummy sashes joined together without mullions.

Flush sash windows can also be made with a deeper frame, so that visually the outer frame, mullions and transoms protrude beyond the sashes, with the sashes being set back into the frame.

Flush window options

There are many different options to choose from of which these are just a few. Windows can be manufactured fully bespoke to suit any situation, for example, special windows for listed buildings, including single glazing, special profile sizes and designs.

1. There are two choices of frame depth: 69mm and 90mm.
2. The outer frame profile can be either ovolo (as shown), or square.
3. The sash shoulder can be either ovolo (as shown), square, or chamfered.
4. The glazing bead can be either chamfered (as shown), ovolo or square.

All the profile choices mentioned above are interchangeable, for example you could have a square outer frame profile, with a square sash shoulder, and an ovolo glazing bead.

The windows can be either externally glazed or internally glazed.

Any shape, style and design is available, but the traditional flush window is the most versatile of all the products. As well as the many options listed above, profiles can be matched, and sashes can be manufactured to accommodate single glazing and slimline sealed units. Traditional ironmongery can be fitted and special size glazing bars made.

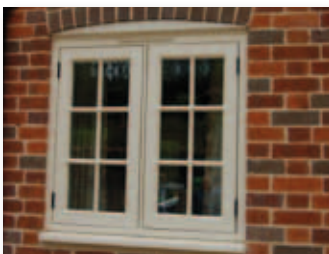
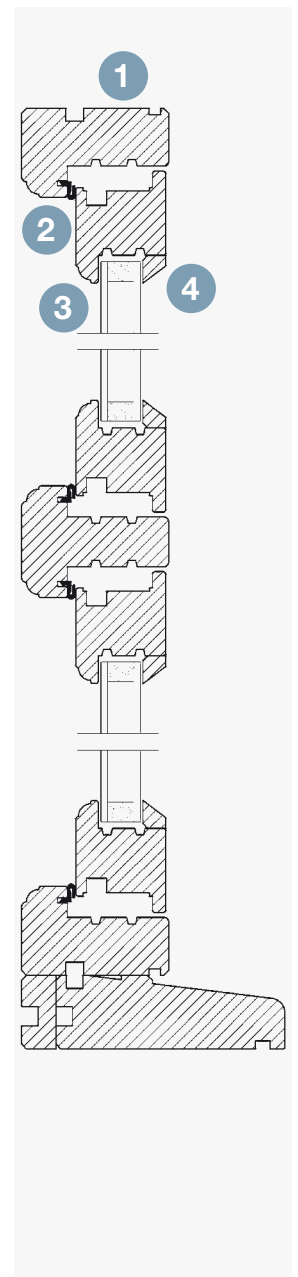

Cream flush window with astragal bars



White flush window with astragal bars, monkeytail handles, and a peg stay



Light oak flush window



Medium oak flush window with cottage bar

We offer a full bespoke service



Stepped Flush Windows

Stepped flush windows

Although the stepped flush window looks virtually the same as the traditional flush window when closed, weatherproofing is vastly improved by using clever and exclusive design techniques, and this is achieved by 'stepping' together the frame and sash on the inside, which enables the stepped flush window to be double-weatherstripped.

The added bonus is that none of the locking mechanisms are visible from the outside; the stepped flush is a clear example of classic looks, new designs and new technologies fusing together.

Modern multipoint shootbolt locking for high security, with a range of shootbolt handles and stainless steel friction hinges makes this a really impressive window.

24mm high-performance sealed units give the optimum 'U' value performance for building regulations approval. 'U' values can be further enhanced by using an even higher specification glass.

Stepped flush window options

There are many different options to choose from of which these are just a few.

1. There is only one depth of frame with the stepped flush window, which is 90mm.
2. The outer frame profile can be either ovolo (as shown), or square.
3. The sash shoulder can be either ovolo, square, or chamfered.
4. The glazing bead can be either chamfered (as shown), ovolo or square.

All the profile choices mentioned above are interchangeable, for example you could have an ovolo outer frame profile, with an ovolo sash shoulder, a chamfered stormproof profile and a chamfered glazing bead.

The windows shown in the detail are externally glazed, but they can also be internally glazed.

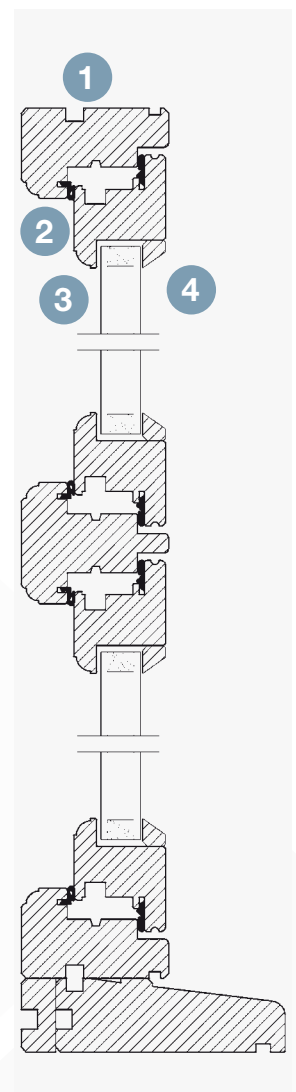

White flush windows with astragal bars



Medium oak window into timber cladding



White flush window with gold handles and leaded glass



Light oak window with monkeytail handles

These stepped flush windows can be made to virtually any shape or size to suit your needs



Sliding Sash Windows

Sliding sash windows

Sliding sash windows can be split into three distinct designs or operating systems: Spiral balances, tilt-and-slide, and weights and pulleys. The difference between the three designs is mainly the mode of operation, although they basically all slide up and down, and their appearance is very similar when fitted, depending on the method of installation.

Spiral balances

Vertical sliding sashes are made using spiral balances, and are based on traditional weights and pulley sliding sashes. They have a traditional appearance and are used extensively for replacements for old weights and pulley windows due to the similarities. They are also the main choice for new-build vertical sliding sash windows, due to the favourable costs. The window furniture comprises traditional fitch fasteners, sash lifts and sash pulls, but the vertical sliding action is achieved by a spring or spiral balances that is weighted to the sash it is connected to, ensuring a smooth operation.

Tilt-and-slide systems

Tilt-and-slide vertical sliding sashes are based on the spiral balance window design. However, they have the additional function of being able to tilt inwards for easier cleaning. There is a clever mechanism fitted into the frame with a catch either side to facilitate the tilting mechanism. This feature means the design and appearance slightly differs on the inside from the traditional window, but they can incorporate all of the ironmongery available on the spiral balances. The vertical sliding operation uses spiral balances weighted to the sash it is lifting to give a smooth operation.

Weights and pulleys systems

Vertical sliding sashes made with weights and pulleys are the traditional method for making sliding sash windows. The use of weights and pulleys is thought to date back to the 17th century, and it is believed they were invented in the UK. Prior to the invention of the sliding sash, windows were similar to traditional flush windows. The operation of the sliding sash is via a pre-determined weight, located in a box section in the outer frame. The weights are connected to the sash with a cord, which nowadays is a pre-stretched nylon sash cord, over a wheeled pulley. This weights and pulleys method of operating gives the smoothest working windows of the three types of sliding sashes.



Light green VSS window with a single vertical astragal bar



White VSS bay window with a single vertical astragal bar to the central window



White VSS bay window with a single vertical astragal bar to the central window



Traditional Finishes

Spiral balances, tilt-and-slide, or traditional weights and pulleys

All the vertical sliding sash window types have 24mm sealed units as standard, and all can be adapted to suit slimline glass, or even single glazing.

There are three standard sash horns shown below, but existing sash horns can be matched if required.

It is also possible to make one-offs and specials, and the spiral balance and weights and pulley windows are ideally suited to bespoke projects such as glazing bars and specific profiles, which often have to be matched.

Sliding sash options

There are three basic designs of sliding sash windows: spiral balances, tilt and slide, and traditional weights and pulleys. The appearance of all three, once fitted, are very similar, the differences being mainly in the operation.

1. The outer frame depth can be either 144mm, or 164mm.
2. The internal staff bead is based on a traditional design with the addition of a brush pile for weatherproofing.
3. The sash shoulder can be either ovolo (as shown), square, or chamfered.
4. The glazing bead can be either ovolo, square or chamfered (as shown).
5. The outer face plate is moulded to mimic the internal staff bead.
6. There are three standard horn designs, but any design can be made.

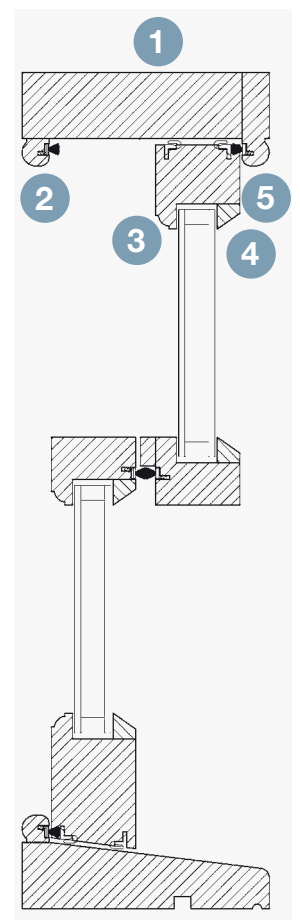

6 Standard sash horns

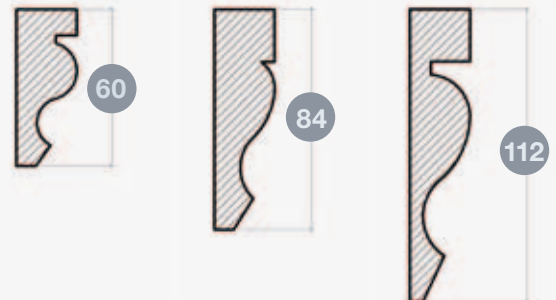

Any size or design of horn can be made on request



Stormproof Doors Flush Doors

Tailor-made to your exact requirements

A range of hardwood doors for external use is available, including front doors, back doors, French doors, stable doors and combination doors. There is a wide range of style and furniture options on all of the doors, too many to list here. If you have a specific requirement, please enquire; experienced designers and engineers with many years of experience in the trade will bring your ideas to life.

All doors, regardless of style and design, are manufactured to the highest standards.

Front entrance doors

A wide range of quality exterior front doors is available, including single side panels and double side panels, either full height or partial height, as required, and are made to measure in any size to form a beautiful entrance to your home. Arched and shaped doors are easily produced in our highly specialised factory.

Double doors, or French doors

French doors or double doors have many advantages in terms of space and flexibility, and the addition of parliament or projection hinge allows the doors to open to virtually 180 degrees, or flat against the walls either side, maximising the light entering the room.

French doors can comprise two doors, with or without sidelights, which can be placed on one side only, or on both sides.

Stable doors

The origins for the stable door date back to the 17th century and were primarily used for keeping children in and animals out, whilst allowing light and air to filter through the open top door. The other advantage was that when the top door was open on a windy day, outside debris blowing in was kept to a minimum. These days, the stable door is a beautiful addition to any home and can be made to look as contemporary or traditional as required, and with modern multipoint locking systems they are equally at home as a front door or a back door.



Front door with raised and fielded panels and a full height leaded sidelight. The sidelight midrail aligns with this door but the head and kick rails do not



Front door with a storey frame and vertical bars aligning with the bars in the door. The frame is white and the door is mahogany



Double doors in a conservatory with locking handles to each door, astragal bars lining through either side and raised and fielded panels below the midrail. The doors are dual colour: green on the outside, white on the inside



Single Doors

Double Doors

Stable Doors

Combination Doors

Combination doors

All doors can accommodate a variety of side and storey frames to make a combination door. These frames can be full height sidelights either to one side or both sides, with or without the kickrails and headrails aligning through, with or without a midrail aligning through, and with or without astragal bars lining through. The attached frame can also be a flag window to one or both sides of the door, or a storey frame above the door, all made to enhance your property.

Door systems

All doors can be made in either a flush system or a stormproof system, depending on your requirements, and these are interchangeable if so desired. Both systems have multipoint locks as standard and there is a whole range of ironmongery currently available, including letterplates, numerals, door knockers, door knobs, spyholes, as well as specialist locks.

Light oak double doors with a locking handle to both master and slave doors, both operating a multipoint locking system



Stylish black front door with a white frame and decorative leaded glass and a storey frame

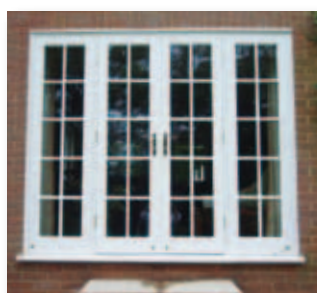



Bifolding Doors

Bifolding doors

Bifolding doors are one of the latest must-have additions to homes, extensions, conservatories and orangeries across the country, and when you see them in action their attraction becomes clear.

Bifolding doors are available in a range of sizes to suit virtually every situation, from a two-door system right up to the impressive six-door configuration. The range is huge, making spans of up to 5.5m possible as standard. With careful design and planning, configurations and sizes these can be exceeded if required.

A room can be transformed by the addition of a bifolding door, and when fully opened lets the outside flood to the inside creating a completely different atmosphere in the room, opening it right up to the outside.

The extra visual space created using bifolding doors is just not possible with French doors due to the high specification track system allowing such wide openings.

There is no compromise on insulation values either, as with a high specification glass, centre pane glass “U” values can be less than 1.0.

The smooth operation of the doors, and the easy-to-operate locking system make these doors a pleasure to use.

Optimum protection and lifespan are assured through manufacturing quality of these bifolding doors, which are built to the same high standards as all other joinery in the collection, and includes the full three-coat factory finish process.



Bifolding doors can be curved as seen here in this light oak conservatory



Situated on the Isle of Wight, this light oak conservatory, its bifolding doors open on a sunny day, takes full advantage of the stunning views



Four-pane bifolding door into a new stone extension. Three doors fold to the right; the single door has a handle and left-hung hinges

‘When a workman knows the use of his tools,
he can make a door as well as a window’

George Eliot, *The Mill on the Floss*.

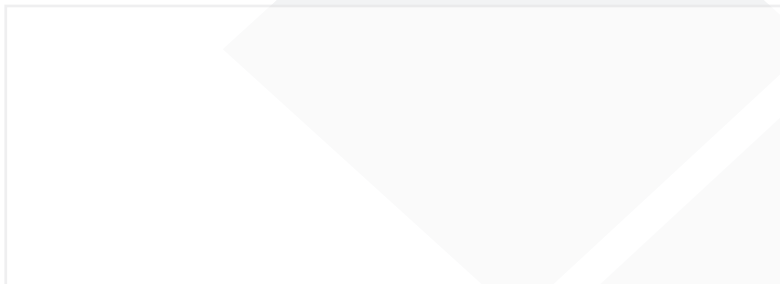

- | | |
|-----------------|--|
| 30 Years | Hardwood with vac-vac treatment
Softwood with vac-vac treatment |
| 10 Years | Standard Hardwood
Sealed Units (factory glazed)
Ironmongery (conditions apply) |
| 8 Years | Paint Finish (conditions apply)
Stain Finish (conditions apply) |
| 5 Years | Sealed Units (fitted on site) |

